

CYMILL HD



HEAVY DUTY MACHINING HEADS

COMPONENTS
PERFECTION.



MADE IN GERMANY



**PROCESS STABILITY
RELIABLE
DYNAMIC
STRONG**

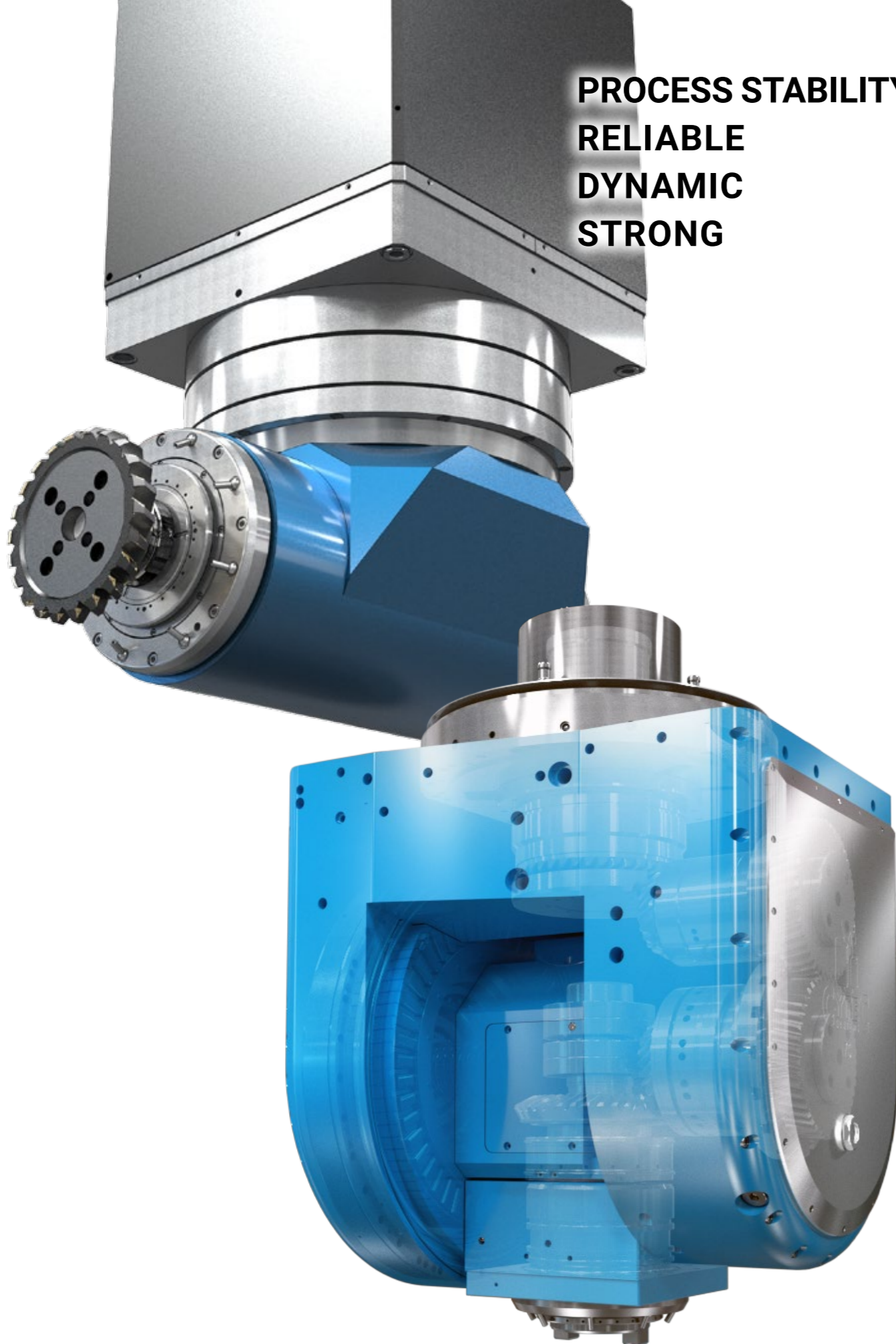

TORQUE FOR HEAVY CUTTING

The CYTEC machining heads from the heavy duty line (HD) are characterised by an especially high rigid design of the housing structure and are equipped with high torque milling spindles for machining of high strength material.

The HD milling heads expand the portfolio of CYTEC machining units by very strong and reliable versions for demanding machining tasks.

Using high capable synchronous motors, the compact T series offers torque values of more than 800 Nm. The two axis K series with planetary geared spindle (in-house development) achieves up to 1,500 Nm.

Beyond these characteristic values, CYTEC offers machining units with geared drives (series I70, AMH and SMH) which are driven by main drive units, reaching torque values up to 2,600 Nm.

The distinctive features of the series are performance, precision and a high level of reliability together with enormous power and dynamics.

The axis drives are characterised by optimal control properties. A high overload capacity adapts ideally to most application requirements.

The powerful axis clamping device supports high precision positioning even for rough machining and high workpiece loads.

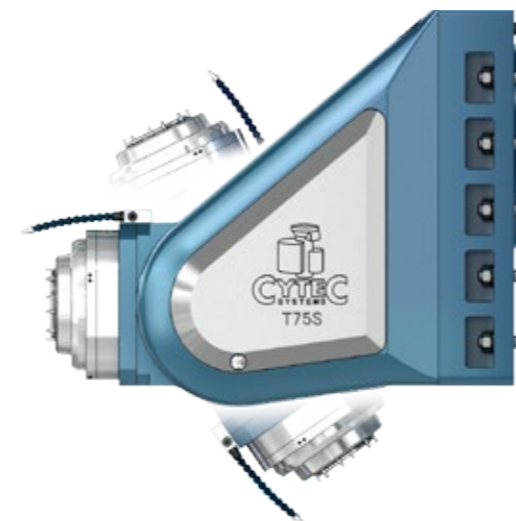

CYTEC Zylindertechnik GmbH is a proven solution provider for mechanical engineering, technical know-how and creativity gained over decades working in the machine tool industry.

The range of products comprises hydraulic and pneumatic clamping systems with self locking, motor spindles, NC rotary tables and as well as single or multiple axis NC milling heads with ultra-high dynamics, patented direct drives. CYTEC Zylindertechnik GmbH is a developer and producer of machine tool components, that meet highest technical demands. Its in-house production depth and flexibility guarantee highest product quality, themed under „**Strongest of its kind**“.

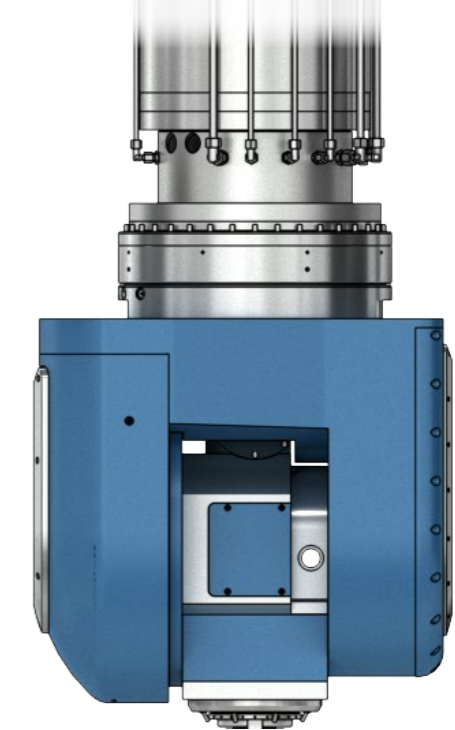



Technical Features:

- Swivel angle +55 up to -135° (negative angle) ①
- Very short pivot for complex internal machining
- Highly robust housing structure and connection to the basic machine
- Swivel torques of the direct drives enable simultaneous machining in high strength raw material (Steel, Titanium)
- Axis clamping allows even higher cutting forces
- Machining spindle with up to 92 kW max.

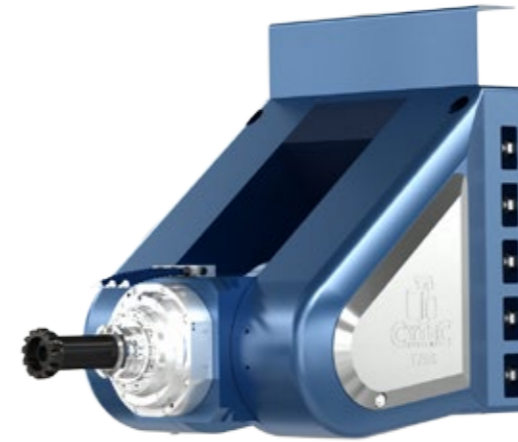
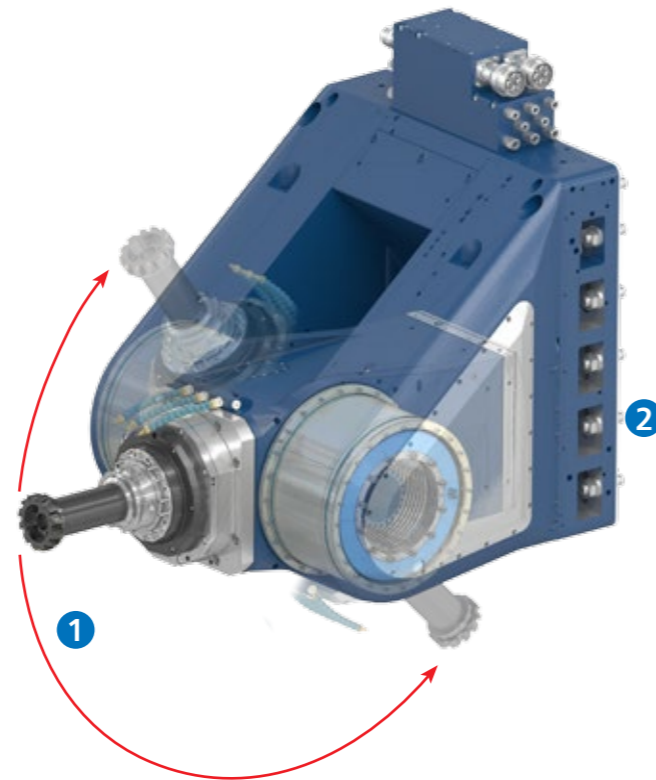

Swivel Head Series T75

	A-Axis
Nenn-/Max. Torque [Nm]:	2.400 / 4.400
Nom. current [A]:	56
Clamping torque 60 bar [Nm]:	6.500
Swivel angle [°]:	-135 / +55
Meas. system:	absolute
Positioning accuracy ["]:	±2,5
Total weight approx. [kg]:	1.650

Series:	CS-73-260-A
Power S1/S6:	73/92 kW
Nom. speed:	1.750 rpm
Torque S1/S6:	398/508 Nm
Max. speed:	15.000 rpm
Tool system:	HSK-A100 / SK-50

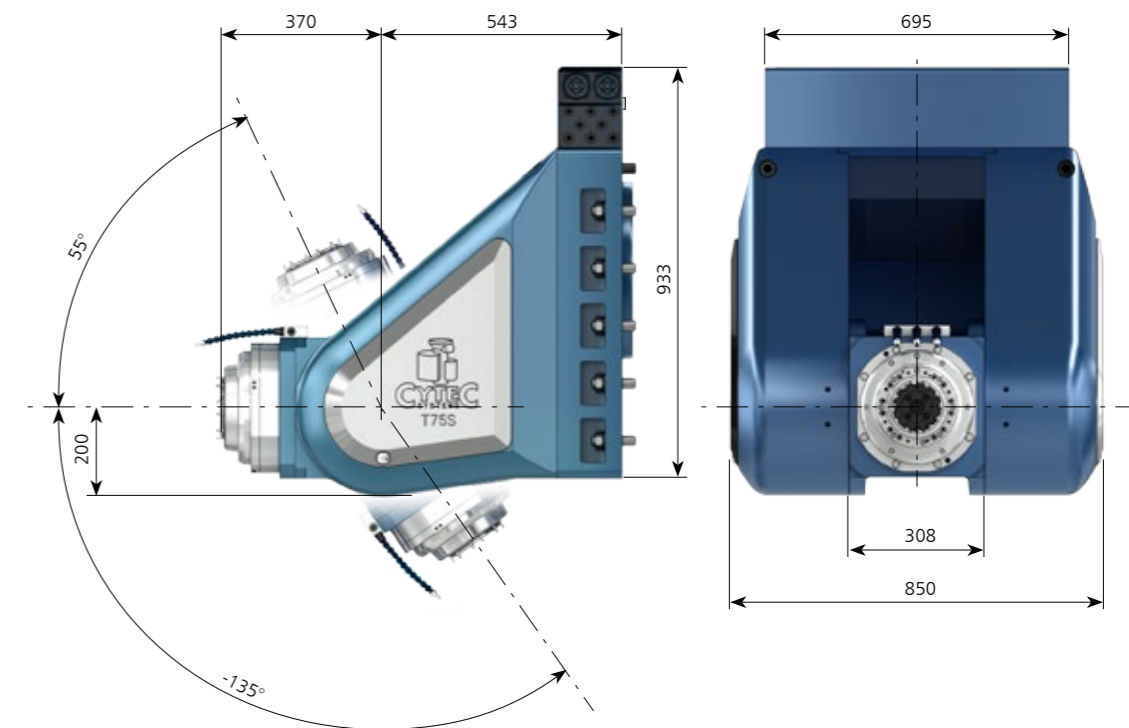
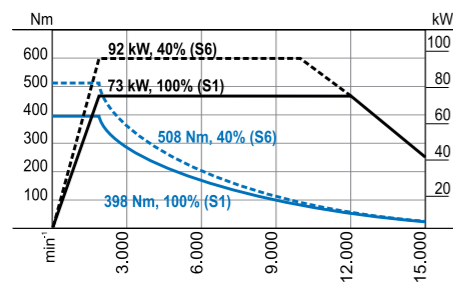

Series K50



Technical Features:

- High speed and high torque in one solution
- Dynamics of a fork milling head combined with torque capacity for rough machining
- Main spindle drive equipped with integrated switchable planetary gear box

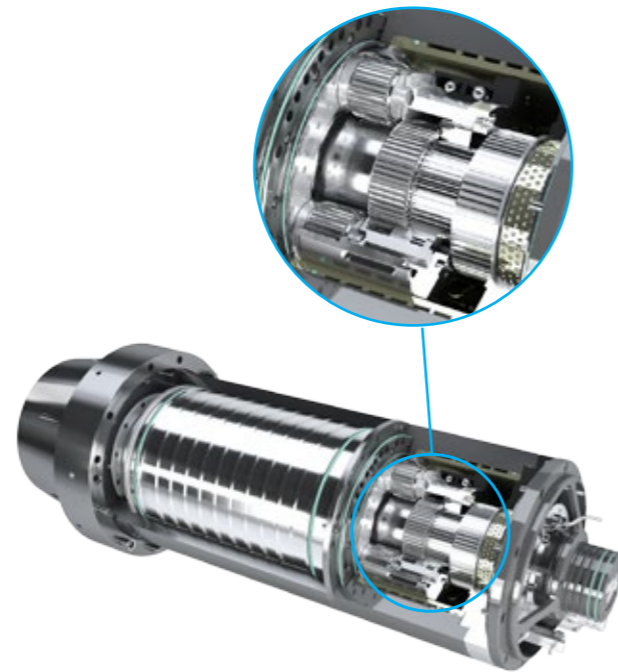

Fork Type Milling Head Series K50

	A-Axis	C-Axis
Nenn-/Max. Torque [Nm]:	7.220/13.400	4.830/7.500
Max. speed [rpm]:	50	40
Nom. current [A]:	92	58
Clamping torque 60 bar [Nm]:	16.000	14.000
Swivel angle [°]:	±120	±360/contin.
Meas. system:	absolute	absolute
Positioning accuracy [°]:	±2,5	±2
Total weight approx. [kg]:	1.760	

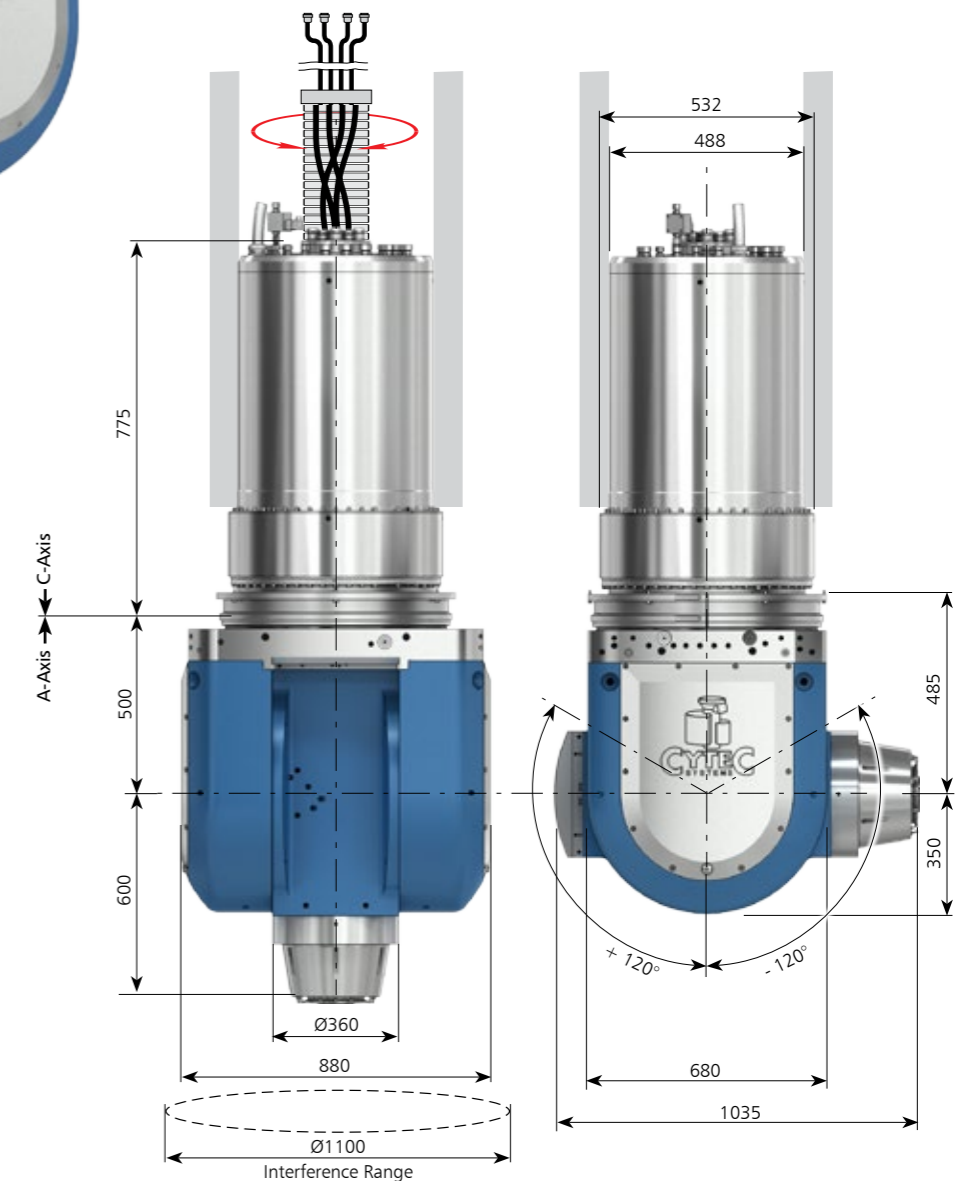

Series:	CSG-76-300-S	
Power S1/S6:	76/95 kW	
Nom. speed:	1.800 rpm (i=1) / 600 rpm (i=3)	
Torque S1/S6:	S1: 400 Nm (i=1) / 1.200 Nm (i=3)	S6: 504 Nm (i=1) / 1.512 Nm (i=3)
Max. speed:	6.000 rpm	
Tool system:	HSK-A100	

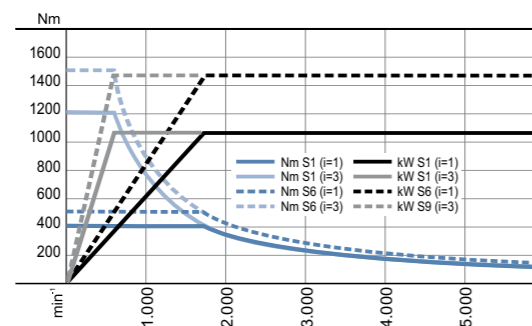

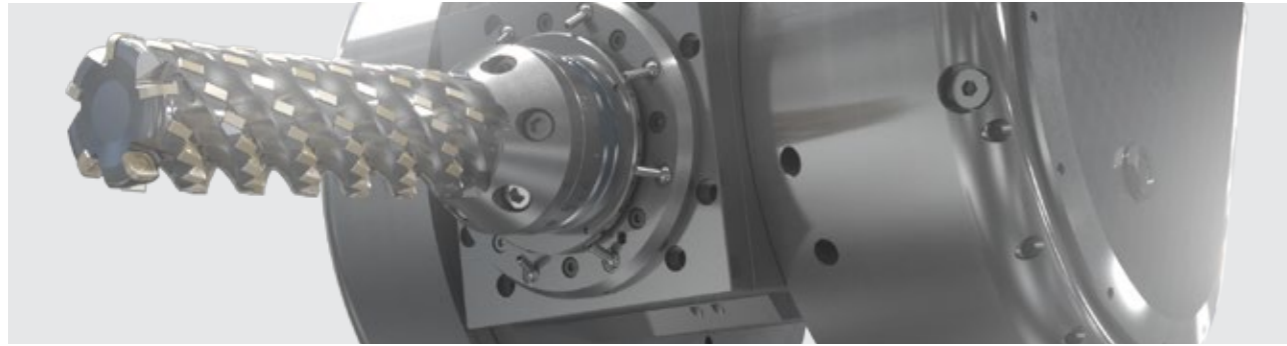

Technical Features:

- Heavy duty machining unit
- Maximal induced torque/speed from the main machine drive **1**
- Option: increased speed with integrated circular lubrication **2**
- Even higher torque for swivel axis and clamping unit
- Fast pickup exchange of power unit **3** by means of hydromechanical automatic docking system with self locking

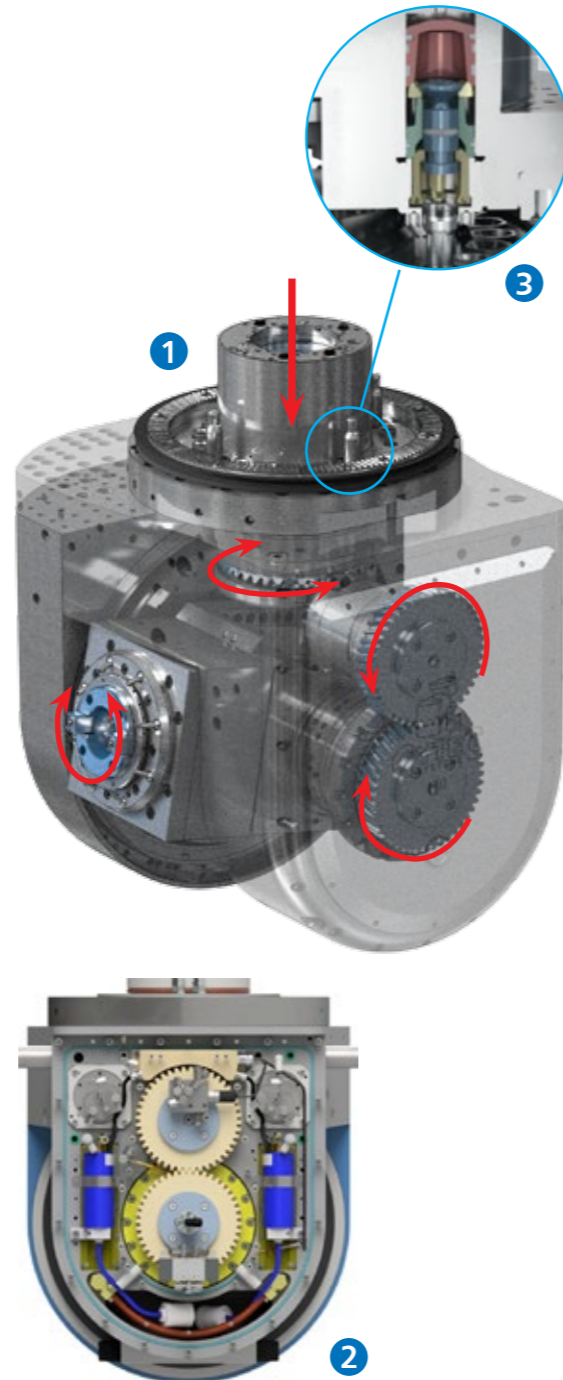

Main spindle	
Output power:	92 kW
Output speed:	595 rpm
Torque S1:	1.470 Nm
Max. speed:	3.000 rpm
Tool system:	HSK-A100

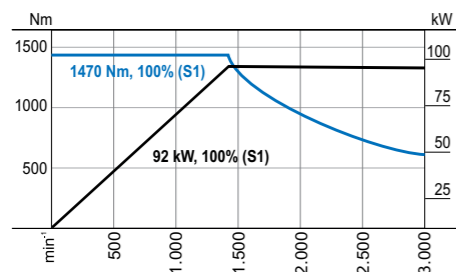

Fork Type Milling Head Series I70

	A-Axis
Nenn-/Max. Torque [Nm]:	1.370/2.540
Max. speed [rpm]:	71
Nom. current [A]:	27
Clamping torque 60 bar [Nm]:	10.000
Swivel angle [°]:	±100
Meas. system:	absolute
Positioning accuracy [°]:	±2
Total weight approx. [kg]:	1.170

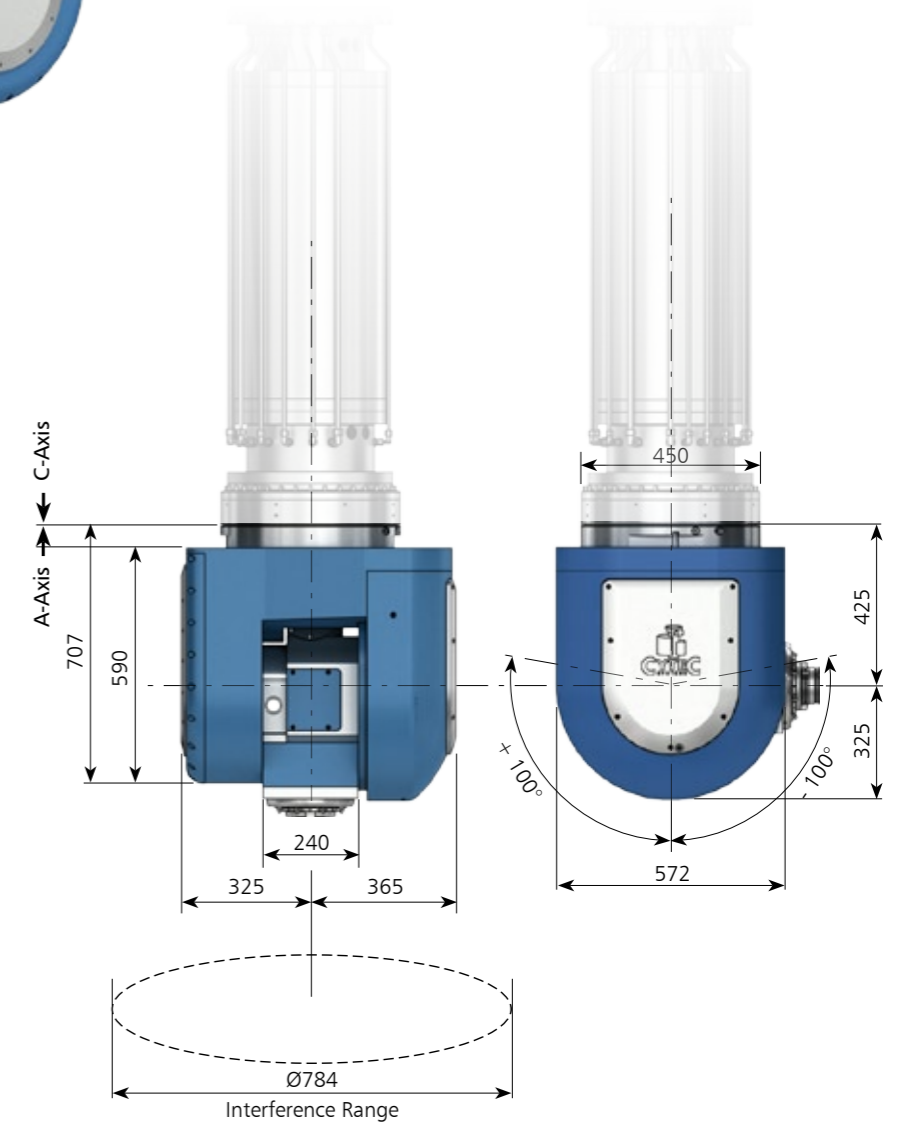



Technical Features:

- Horizontal milling-/drilling unit, tilting angle +/- 180°, by 1° steps ①
- Integrated, pivotable C axis with proven CYTEC clamping functionality and torque transmission by means of Hirth coupling with self locking; swivel function actuated by the machine main drive ②
- Very compact design for short lever arms
- Option: individually adaptable to machine-specific or CYTEC standard head interface

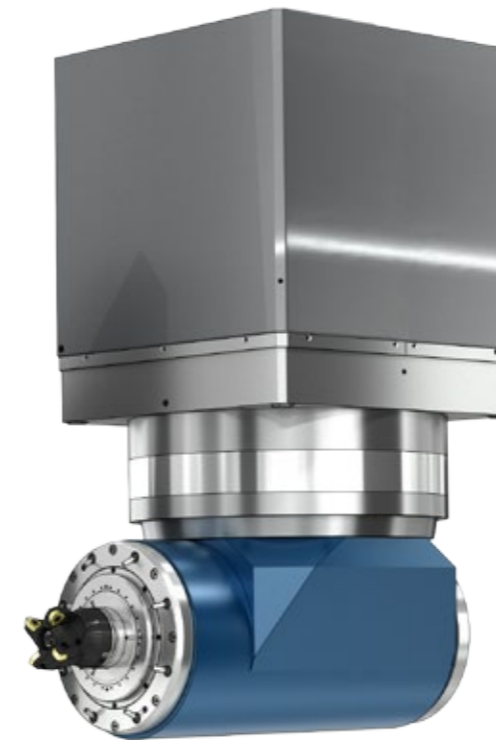
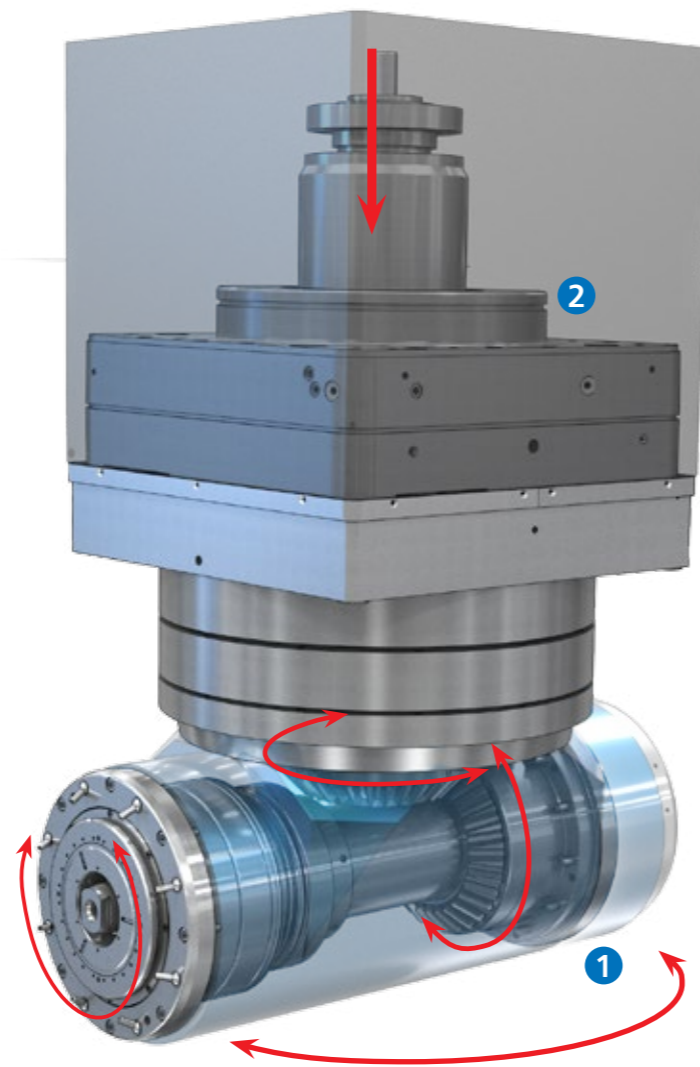

Angular Milling Head AMH

	Attachment unit
Nominal Torque [Nm]:	2.600 (S1)
Power [kW]:	60
Swivel angle [°]:	0/180 (in 1° steps)
Speed range [rpm]:	0 - 2.500
Positioning accuracy ["]:	±2
Total weight approx. [kg]:	920

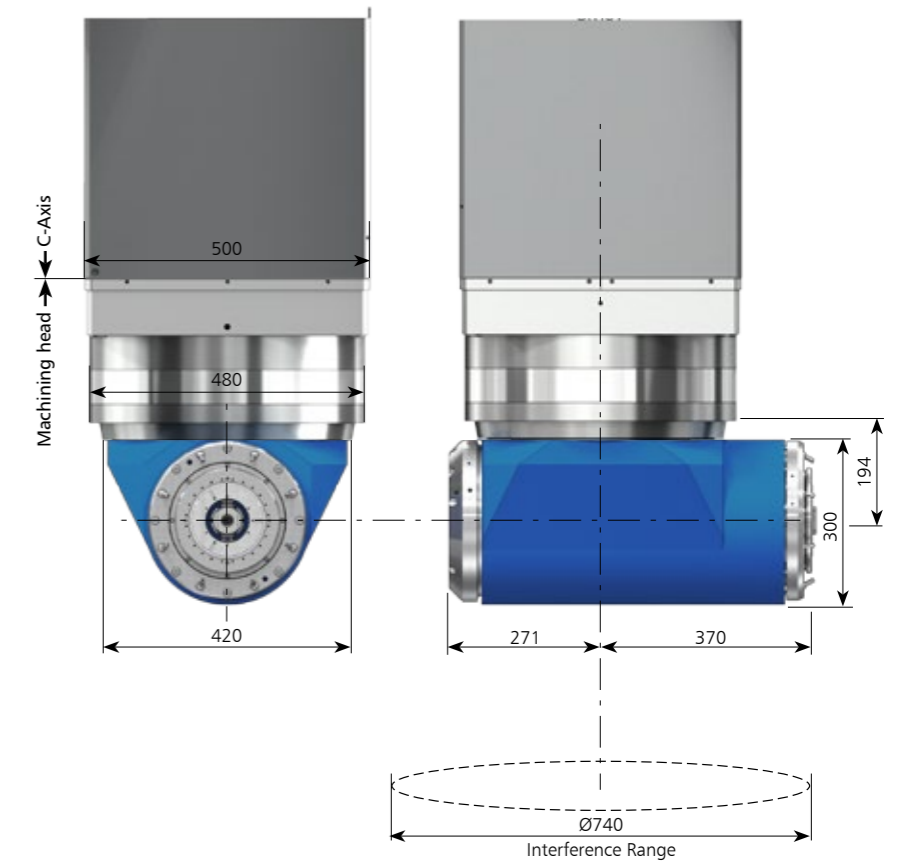

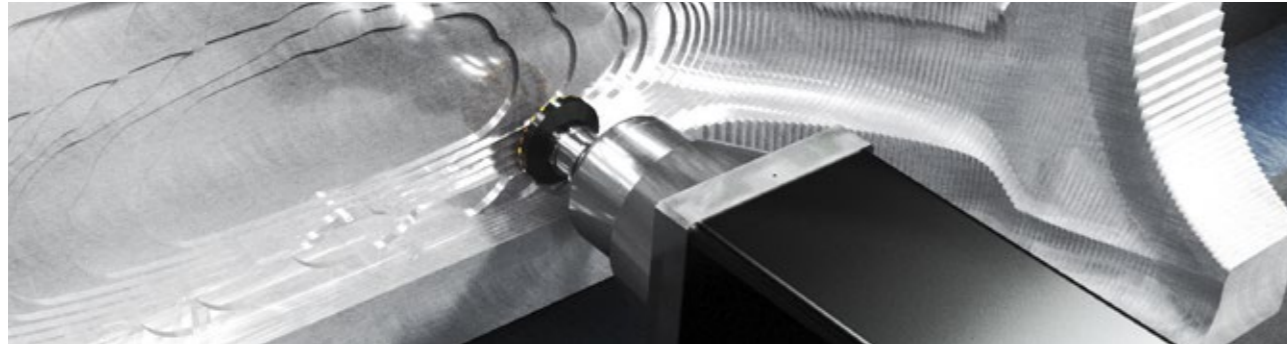

Technical Features:

- Milling-/drilling head attachment
- Horizontal or vertical installation to machine tool
- Docking with proven CYTEC clamping functionality and torque transmission by means of Hirth coupling with self locking device
- Very compact design for short lever arms
- Option: individually adaptable to machine-specific or CYTEC standard head interface



Straight Milling Head SMH

	Attachment unit
Torque [Nm]:	2.500 (S1)
Power [kW]:	60
Speed range [rpm]:	0 - 4.000
Tool interface:	HSK-A100
Total weight approx. [kg]:	570

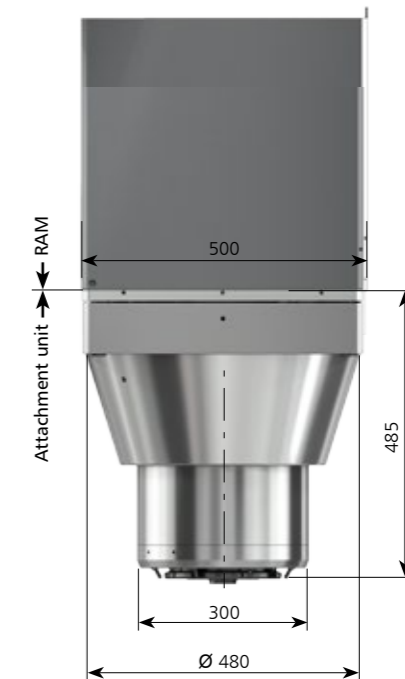

SERIES G30 GRINDING HEAD



Technical Features:

- Perfect grinding surfaces by means of minimised vibration and highly balanced structure
- Easy exchange of the grinding disc with HSK interface
- Automatic head exchange for highest flexibility
- Direct axis drives guarantee outstanding precision
- Option: integrated balancing device and vibration sensor technology



Grinding Head G30-G

	A-Axis
Torque S1/S6 [Nm]:	2.740 / 5.080
Max. speed [rpm]:	60
Nom. current [A]:	54
Clamping torque 60 bar [Nm]:	8.000
Swivel angle [°]:	±110
Meas. system:	absolute
Positioning accuracy [°]:	±2
Total weight approx. [kg]:	950

Series:	CS-36-238-A
Power S1:	36 kW
Nom. speed:	1.950 rpm
Torque S1:	175 Nm
Max. speed:	3.000 rpm
Tool system:	HSK-A125

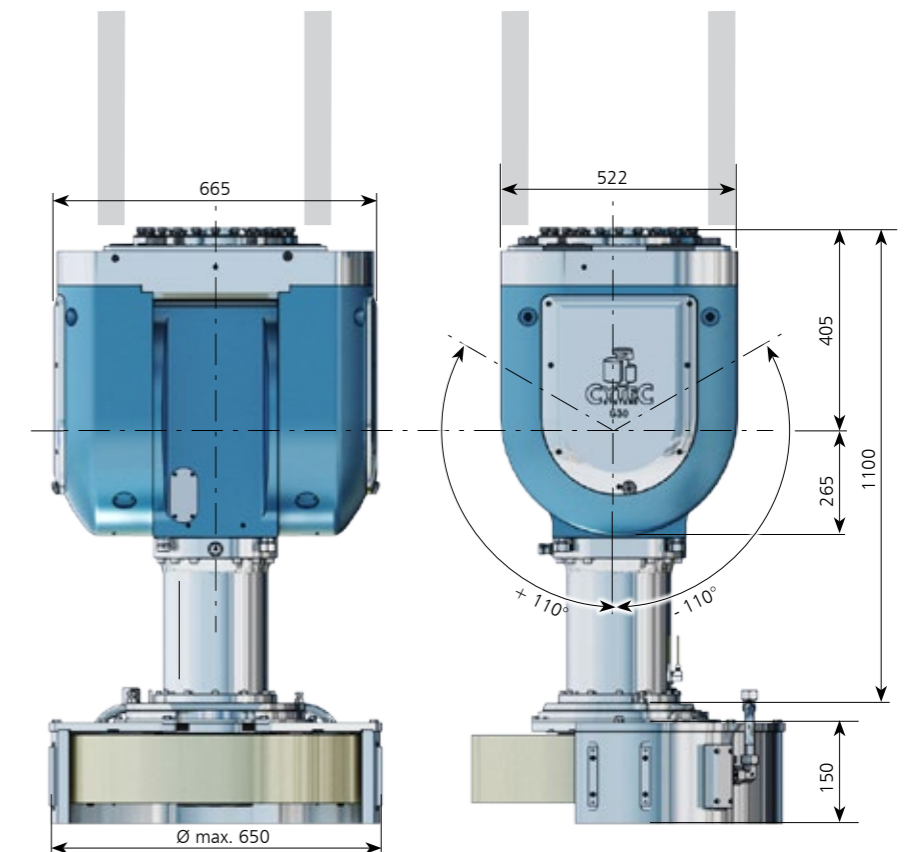
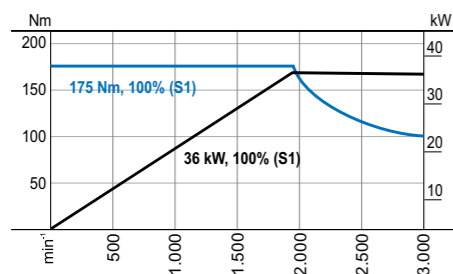



CYTEC WORLD WIDE

● Sales & Services, Home Address and Subsidiaries:

Jülich, Germany | Pliezhausen, Germany | Oldham, Great Britain
Le Vésinet, France | Leiria, Portugal | Milano, Italy | Liberec, Czech Republic
Schwarzenburg, Switzerland | Donaújváros, Hungary | Port Saint Lucie, USA
Anaheim, USA | Aragua, Venezuela | Indianópolis, Brazil
Shenyang City, China | Taichung City, Taiwan



CYTEC Zylindertechnik GmbH

Steffensrott 1 • D-52428 Jülich

Tel.: (+49) 2461 / 6808-0 • Fax: (+49) 2461 / 6808-758

E-mail: info@CYTEC.de • [http:// www.CYTEC.de](http://www.CYTEC.de) • www.CYTEC.blog



CyMill_HD_01 | 08/2022 | english

We reserve the right to make technical modifications. The components/ machines shown here may include options, accessories and control variants.